

NEOPRENE COVERED CABLE (S00 16/4) APPROX. 6'-0" LG.

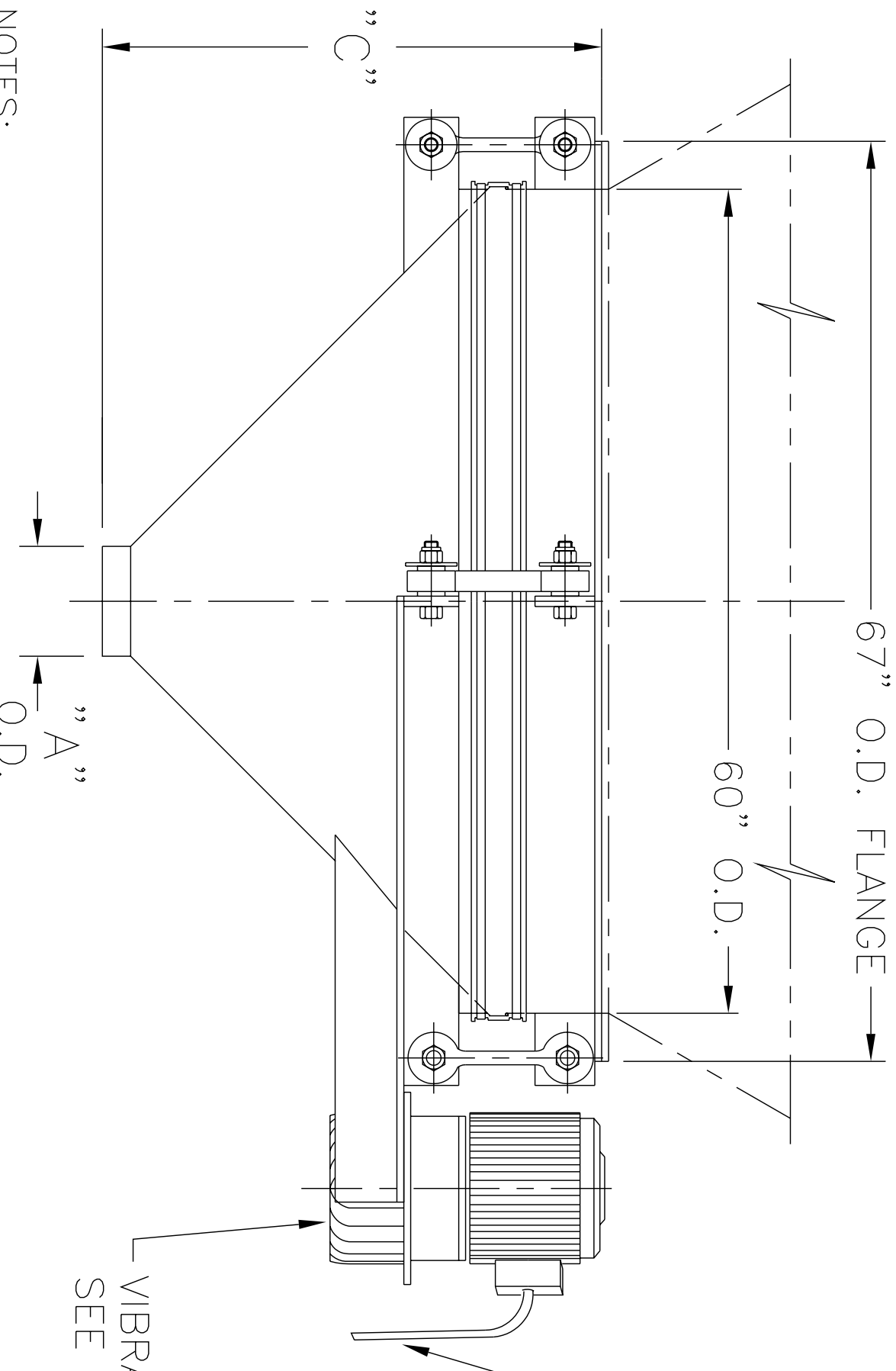

"A" O.D.	"C"
8" O.D.	36 3/8"
10" O.D.	35 3/8"
12" O.D.	34 3/8"
14" O.D.	33 3/8"

THE RECIPIENT OF THIS DOCUMENT AGREES NOT TO REPRODUCE, COPY, TRANSMIT OR USE THIS DOCUMENT AND/OR THE INFORMATION CONTAINED IN THIS DOCUMENT IN WHOLE OR IN PART, FOR ANY PURPOSE, EXCEPT WITH THE WRITTEN PERMISSION OF VIBRA SCREW INCORPORATED.

- NOTES:
- 1 - CONTACT MATERIAL: CARBON STEEL, 304 S/S, 316 S/S.
 - 2 - GYRATOR DRIVE TO BE: 2 HP, T.E.F.C., 1750 RPM, 230-460/3/60
 - 3 - ALL ELECTRICAL CONNECTIONS TO BE FLEXIBLE
 - 4 - ALL CONNECTIONS TO BIN DISCHARGER MUST BE FLEXIBLE

Vibra Screw Incorporated
 755 Union Blvd. Totowa, N.J. 07512-2207

TITLE: 5'-0" DIA. BIN DISCHARGER CENTER FLAT STOCK AND 3 K GYRATOR

DWN / DATE: MJM 8/22/01

CAD FILE NAME: N:\BA\BD\STDASSY\17978-SD

DWG. NO.: 17978-SD

REV. NO.: 1